

1

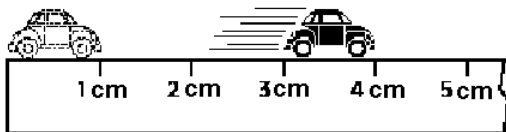

What is the speed of the toy car shown above if it moves through the distance shown in two seconds?

- (A) 1.5 cm/s
- (B) 2 cm/s
- (C) 2 cm/s²
- (D) 3 cm

2

What is the volume of the liquid in the graduated cylinder?

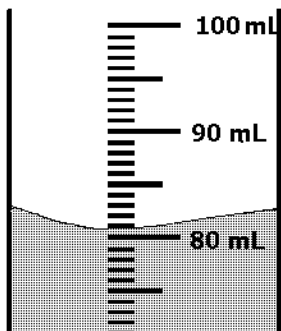

- (A) 82.0 mL
- (B) 81.5 mL
- (C) 81.0 mL
- (D) 99.0 mL

3

An aerodynamically improved motorcycle for racing was built. The model was tested for high speed in a wind tunnel. The new model was able to achieve higher speeds than the current model. When the new model was driven on the highway, the motorcycle and cyclist were blown off the road when another vehicle passed. What was the problem with the new model?

- (A) The wind tunnel did not account for the interactions with other forces, such as those produced by the passing vehicle.
- (B) The cyclist was inexperienced and did not know how to handle a motorcycle under intense conditions.
- (C) The prototype was built according to the old model rather than the new plans.
- (D) The other vehicle was traveling faster than the speed limit allowed.

4

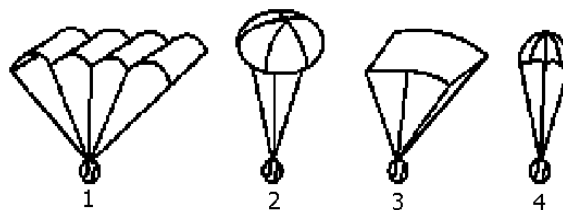

If these four identical balls are dropped at the same time and from the same height, which ball will land first?

- (A) 1
- (B) 2
- (C) 3
- (D) 4

- 5 The table below shows the distance traveled and time elapsed for each object as it moves from points A to B and from B to C. Positions of A, B, and C are different for each object.

Object	From A to B		From B to C	
	Distance	Time	Distance	Time
1	2.6m	2.0s	1.3m	1.0s
2	1.8m	1.2s	3.6m	1.2s
3	4.0m	5.5s	3.0m	4.0s
4	5.0m	5.0s	4.5m	3.5s

Key
m=meters
s=seconds

Objects 1, 2, 3, and 4 are moving in straight lines from point A to point B and then from points B to point C. All objects contain the same mass.

Which object has no change in force applied from point A to B as it did from B to C?

- (A) Object 1
 (B) Object 2
 (C) Object 3
 (D) Object 4
- 6 Which of the following objects is MOST likely to be slowed by the force of gravity?
- (A) A car rolling up a hill
 (B) A ball rolling on flat ground
 (C) An airplane flying on a level course
 (D) A skydiver falling toward Earth
- 7 What must be true for a car to move forward at a constant speed? The forward force of the car is
- (A) increasing at a constant rate.
 (B) greater than the force of gravity.
 (C) balanced with the force of friction.
 (D) greater than the backward force on the car.

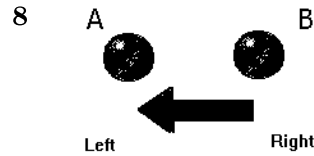

Examine the diagram above. Marble B is rolling at a constant speed until it strikes marble A. What will happen to the marble A when it is struck by marble B?

- (A) Marble A will remain in the same position.
 (B) Marble A will begin to accelerate to the right.
 (C) Marble A will be accelerated to the left.
 (D) Marble A will be shattered into pieces.
- 9 Which of the following graphs represents a train moving with constant speed?

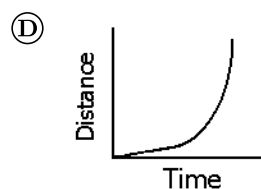
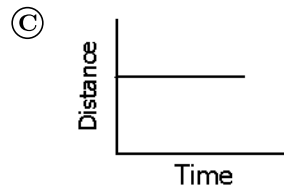
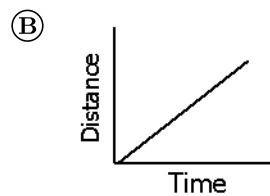

10 Jill designed a ramp to roll a marble down. She changed the ramp's incline and did five trials each time. What would be the best way to record her results?

- (A) Measure how far the marble travels each time and the height of the inclines. Graph the results.
- (B) Measure the circumference of the marble and the height of the inclines. Graph the results.
- (C) Measure how far the marble travels each time and graph the results.
- (D) Average the distance traveled on all trials and graph the results.

11

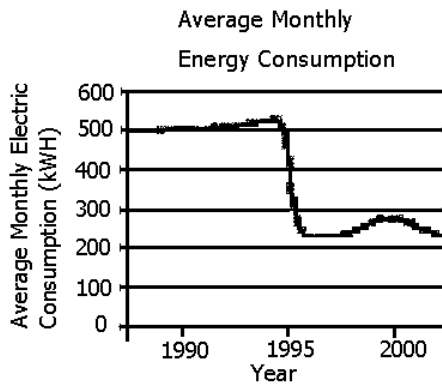

Which inference is BEST supported by the data?

- (A) A child moved away to go to college in 2001.
- (B) Large solar panels and large windows were installed in 1990.
- (C) Energy-efficient appliances were purchased in 1995.
- (D) The family was out of town for extended periods of time in 1992.

12 Forces that act on objects can affect their speed and direction.

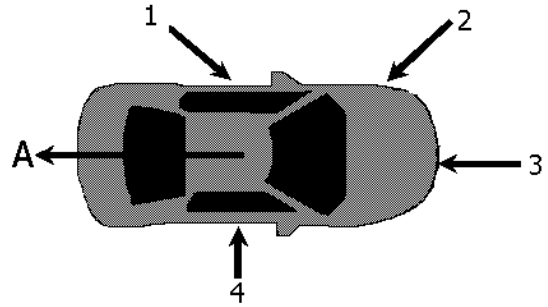

A car is traveling down the street in direction A. Which of the forces shown in the figure above would affect ONLY the speed of the car?

- (A) 1
- (B) 2
- (C) 3
- (D) 4

13 A soccer ball that is kicked will stay in motion until an equal force is exerted on the ball and it stops rolling. Which of these forces, when exerted on the ball, would be equal to the force of the kick and stop the ball from rolling?

- (A) Gravity and friction
- (B) Friction and inertia
- (C) Inertia and gravity
- (D) Magnetism and friction

14



The swing shown above is attached to the tree with knots. When a person sits on the swing, which of the following forces helps keep the swing from falling?

- (A) Friction
- (B) Tension in ropes
- (C) Gravity
- (D) Weight of student

15



A student throws a ball to a friend. Which of the following causes the ball to fall downward?

- (A) Catching the ball
- (B) Friction of the air on the ball
- (C) Gravitational pull of Earth
- (D) Throwing the ball

16 A student takes her bicycle apart. She spreads all the parts out on the floor. Which property of the bicycle has been lost?

- (A) The parts no longer stick to a magnet.
- (B) The parts no longer work together as a machine.
- (C) The parts will not rust when left outdoors.
- (D) The parts no longer have a combined mass of 10 kg.

17 A student drops a beaker on the floor, breaking it. Which of the following should the student do FIRST?

- (A) Tell the teacher about the accident.
- (B) Find a new beaker to use.
- (C) Look for a broom and dustpan.
- (D) Put on heavy gloves.

18

Force of textbook = 9N
Area of textbook = 0.3 m^3



Which of the following accurately describes the forces acting on the book and table shown in the diagram above?

- (A) The book exerts more force on the table than the table exerts on the book.
- (B) The table exerts more force on the book than the book exerts on the table.
- (C) The forces are balanced.
- (D) The forces are unbalanced.

- 19 A student rolled a marble across the floor. The marble rolled at a constant speed until it collided with a second marble. After the two marbles collided, they rolled at a constant speed in different directions. In which of the following instances are the forces unbalanced?
- (A) The first marble rolls at a constant speed in a straight line.
 - (B) The second marble sits motionless on the floor.
 - (C) At the moment of collision, the motion of the first marble changes direction and the second marble starts moving
 - (D) Both marbles are moving at a constant speed in straight lines away from the location at which they collided.

20

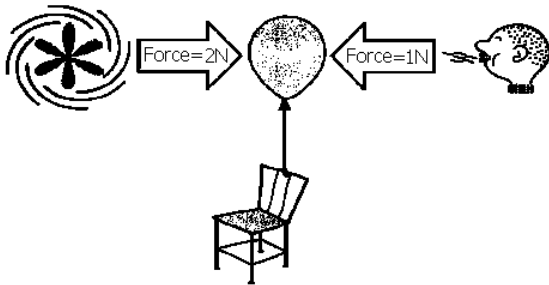





A party balloon is tied to the back of a chair. A fan is blowing across the room with a force of 2 newtons. A child is blowing on the other side of the balloon with a force of 1 newton. In what direction will the balloon move?

- (A) The balloon will move to the left.
- (B) The balloon will move upward.
- (C) The balloon will move to the right.
- (D) The balloon will move downward.

- 21 A student places a brick measuring 2 inches by 4 inches by 8 inches on a ramp and measures the amount of force needed to pull the brick up the ramp. The student repeats the experiment five times, keeping everything the same except the way the brick is placed on the ramp. In each trial, the student turns the brick so that it sits on a different face. Which of the following questions is the student MOST likely trying to answer?

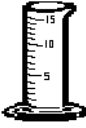
- (A) How is the roughness of the ramp related to friction?
- (B) How is surface area related to friction?
- (C) How is the height of the ramp related to friction?
- (D) How is mass related to friction?

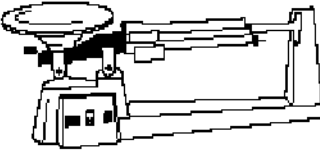
- 22 A student needs to measure the mass of an apple. Which of the following tools should the student use?

- (A) 
- (B) 
- (C) 
- (D) 

23 Students cut 1-inch by 1-inch squares of several brands of paper towels. They followed the procedure below.

1. Measure water volume. 2. Dip square into room temperature water. 3. Wait one minute. 4. Remove square. 5. Measure final water volume.

The students decide to graph their results. Which variable should the students place on the x-axis?

- Ⓐ Paper towel brand
- Ⓑ Size of paper towel
- Ⓒ Temperature of water
- Ⓓ Water absorbed by paper towel

24 Two companies make golf balls, and each claims that its ball goes farther. Which would be the best scientific evidence to decide which ball goes farther?

- Ⓐ The best golfer in the world hits each ball 100 times, and you measure how far each goes.
- Ⓑ A machine hits each ball with exactly the same force, and you measure how far each goes.
- Ⓒ You read results of tests conducted on the two balls by each company.
- Ⓓ You ask the best 100 golfers in the world which ball goes farther.

25 In which of the following situations are the forces unbalanced?

- Ⓐ As a cart rolls down a ramp, its speed increases.
- Ⓑ A cart lies on its side at the bottom of a steep hill.
- Ⓒ Two children pull on a cart in opposite directions, but the cart does not move.
- Ⓓ A man pushes a cart at a constant speed along a straight path.

26 Free Response

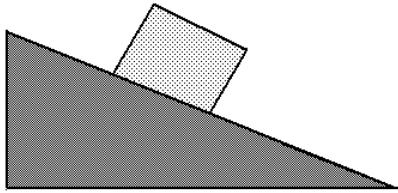

A box sits on an inclined ramp without moving.

1. Explain why the box does not slide down the ramp.
2. What would cause the box to start sliding downward? Explain your answer.

- 27**
1. Using string, a set of weights, masking tape, a ruler, and a book, design an experiment that would demonstrate the effects of a force on an object's motion and location. (Draw and explain)
 2. Identify the force or forces at work, the object being acted upon, and the effects the force or forces would have on the object.